



## **COMPANY PRESENTATION**



# COMPANY INFORMATION

**1945: Company Drina, Radovan was founded**

**1992: Start of production of car hydraulic lifts**

**1997: Establishing of AUTO MOTIVE INDUSTRIAL a.s.**

**2010: AUTO MOTIVE INDUSTRIAL is fully owned by two Czech auctioneers**



### Production

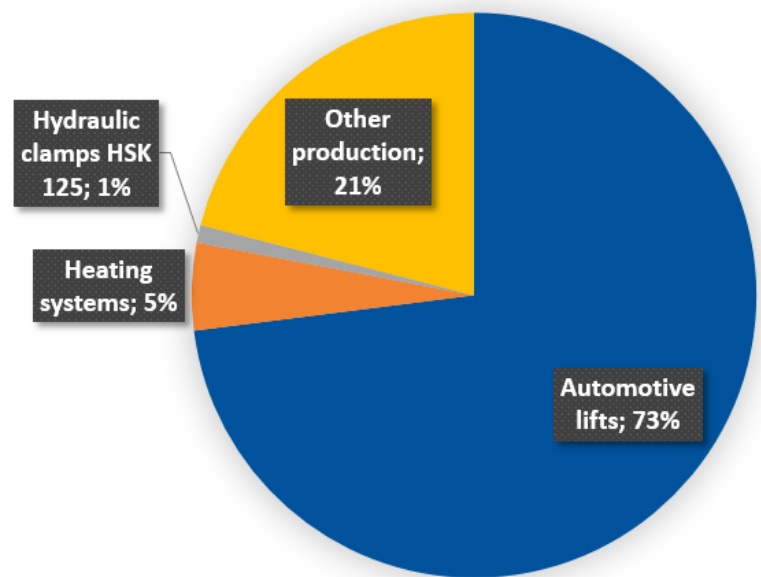

### Export (click the chart to see)

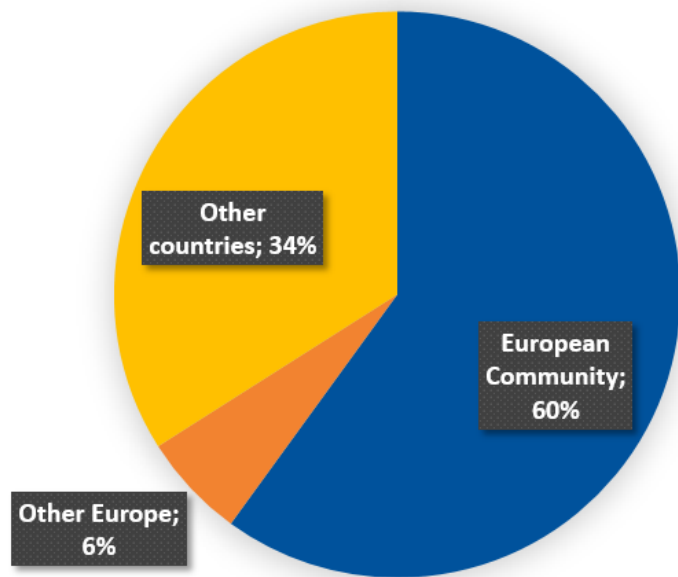

# PRODUCT PORTFOLIO

ČSN EN 1493:2010





## 2 POST HYDRAULIC LIFTS



**AMI 3,0 ECO LINE**



**AMI 3,6 CLASSIC**



**AMI 4,0 VARIANT**





## 2 POST HYDRAULIC LIFTS

**Loading capacity 5,5 tons**

**Arm types – 3D, 3D EX**

**Easy operation with lever or buttons**

**Highly efficient and economical**

**Variability in post extension**

**Next-gen rubber pads**

**Usable for VANS**



**AMI 5,5 VAN**







**AMI 8,0 BUS**

**Loading capacity 8 tons**

**Extended arms 900 – 2000 mm**

**Easy operation from both posts**

**Highly efficient and economical**

**Automatic release of safety latches**

**Usable for VANs and smaller buses and trucks**





# 2 POST HYDRAULIC LIFTS

## Packaging

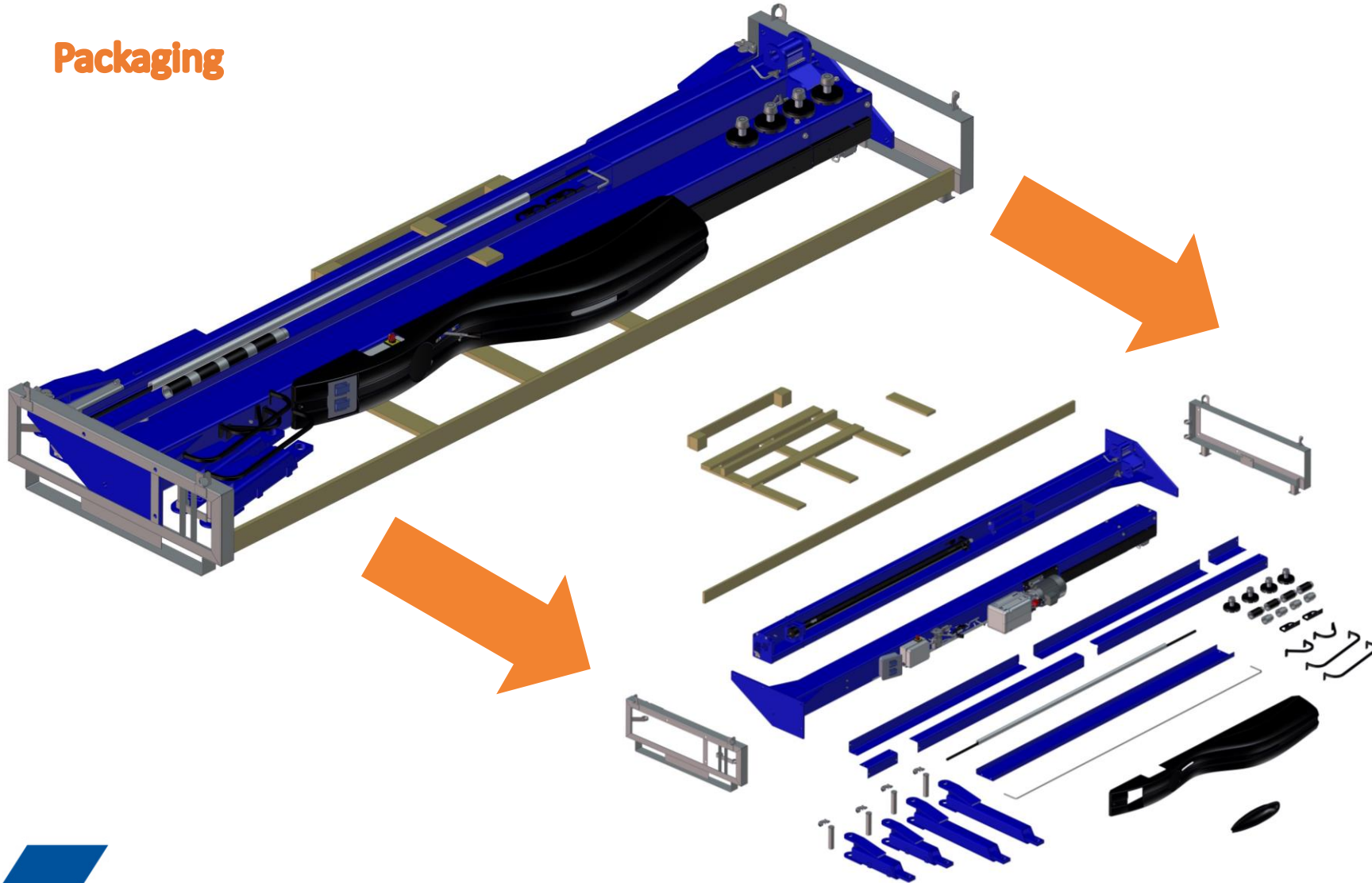



# 2 POST HYDRAULIC LIFTS

To ease the assembling at place

Tubular spanner

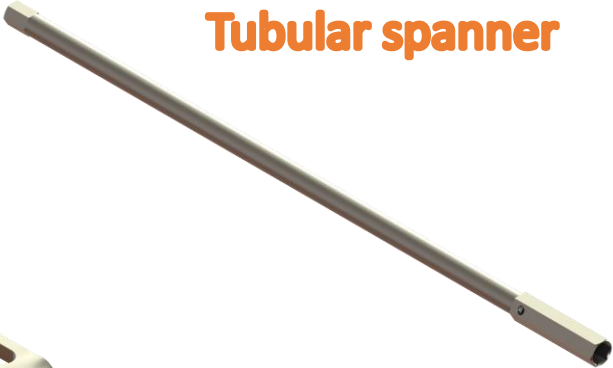

Flat spanner



Drilling templates

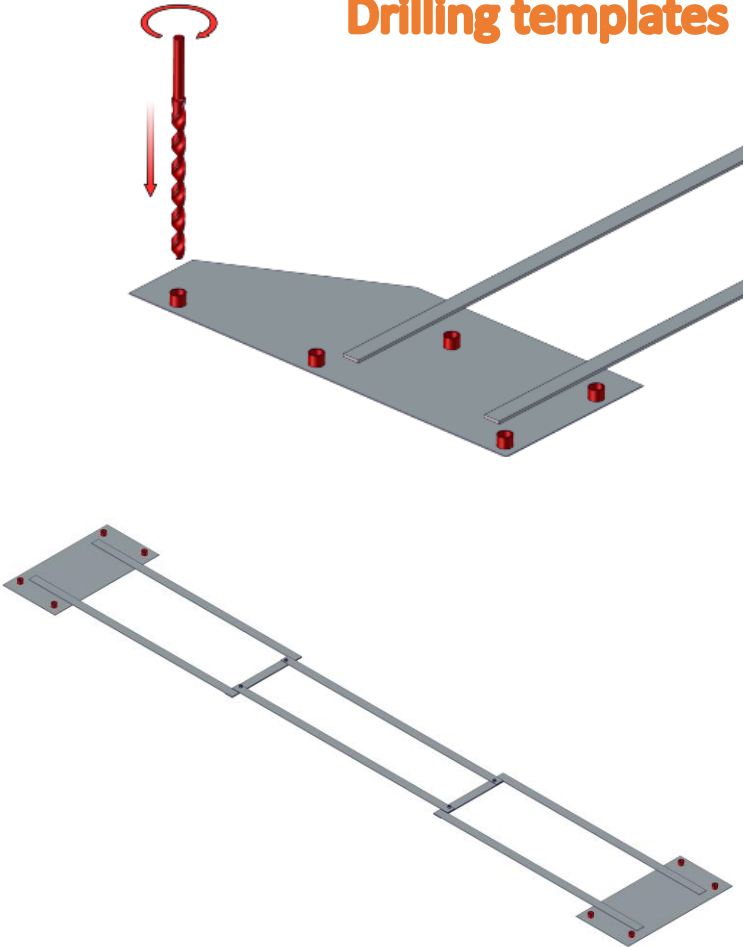





## 4 POST HYDRAULIC LIFTS

**Loading capacity 4 – 5,5 tons**

**Highly efficient and economical**

**Length up to 5.450 mm**

**Adjustable platforms**

**Wide range of accessories**

**Integrated scissor lift**

**Designed for 3D wheel alignment**





# 4 POST HYDRAULIC LIFTS

## Accessories

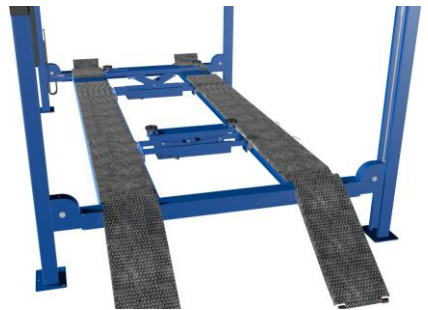
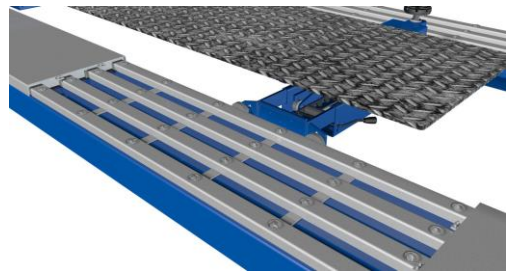



# 4 POST HYDRAULIC LIFTS

## Packaging

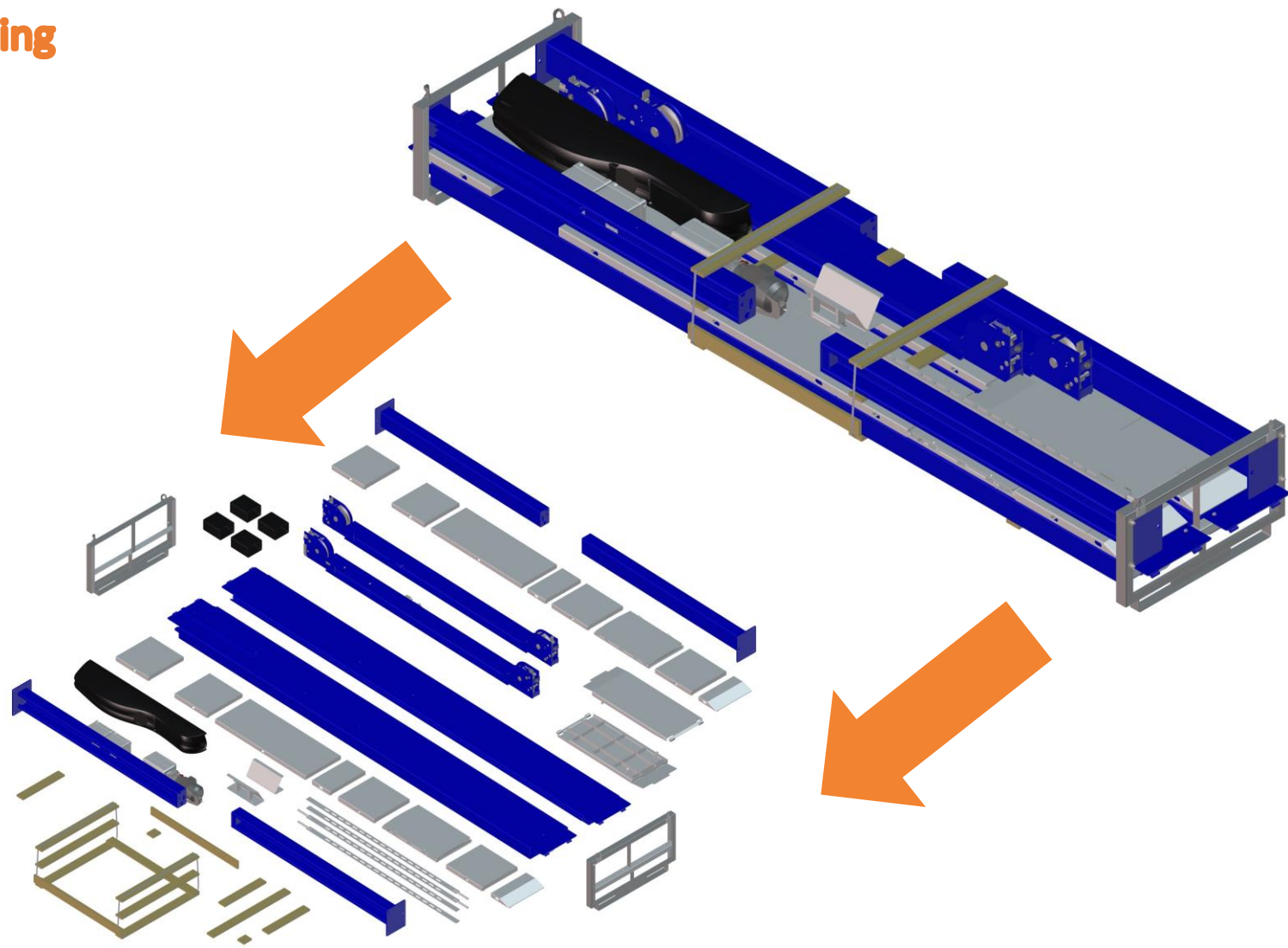



# SINGLE COLUMN HYDRAULIC LIFTS

Loading of each column 5,5 or 7,5 tons

Highly efficient and economical

Electronic regulation and synchronization

Tablet with touch screen or remote control

Enlargement 4-12 posts

Tandem function

Lifting of broad range of vehicles from delivery VANS to off-highway trucks

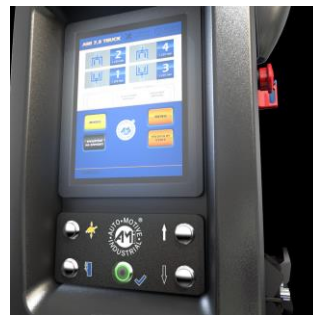



# SINGLE COLUMN HYDRAULIC LIFTS

## 6 column version

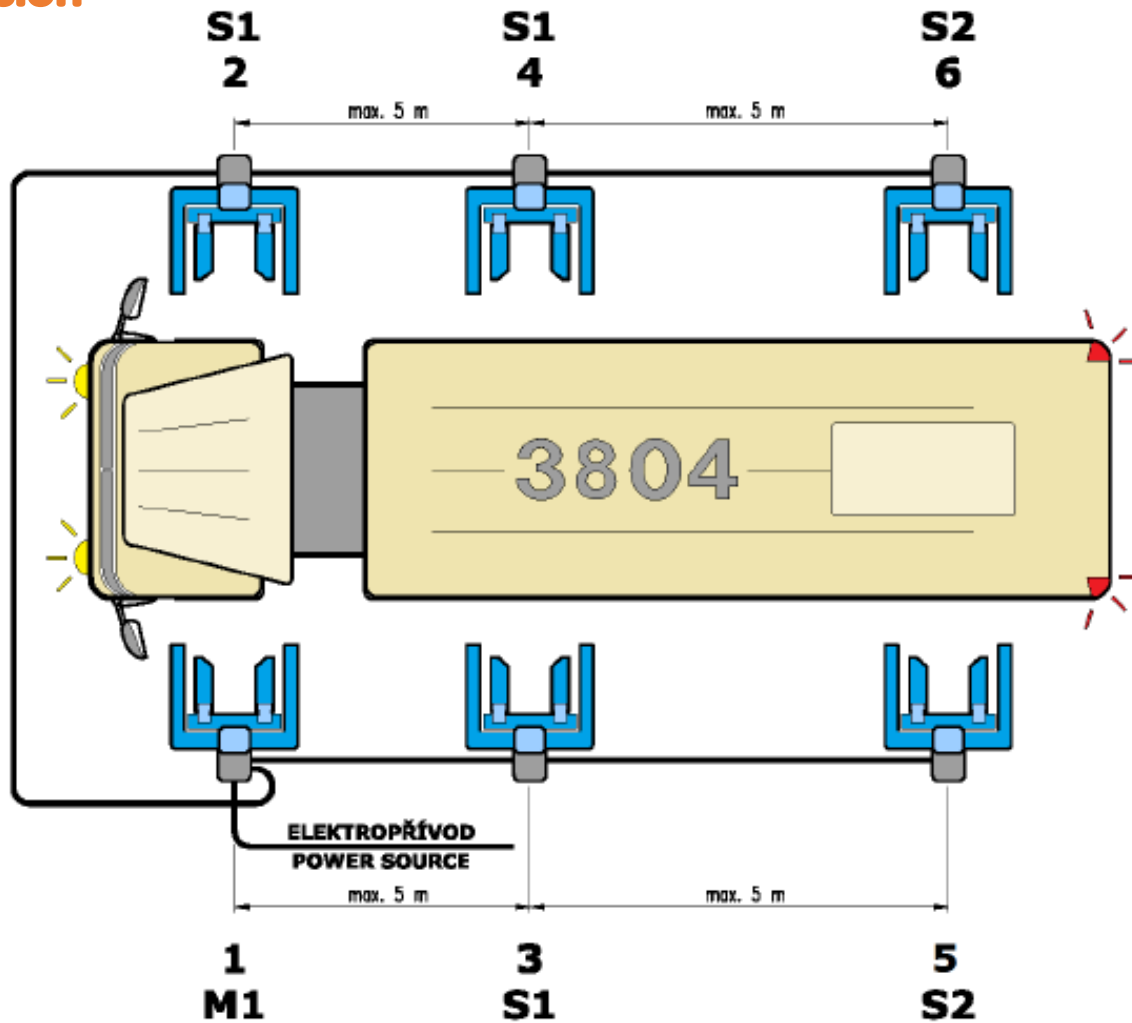





# SINGLE COLUMN HYDRAULIC LIFTS

## 12 column version

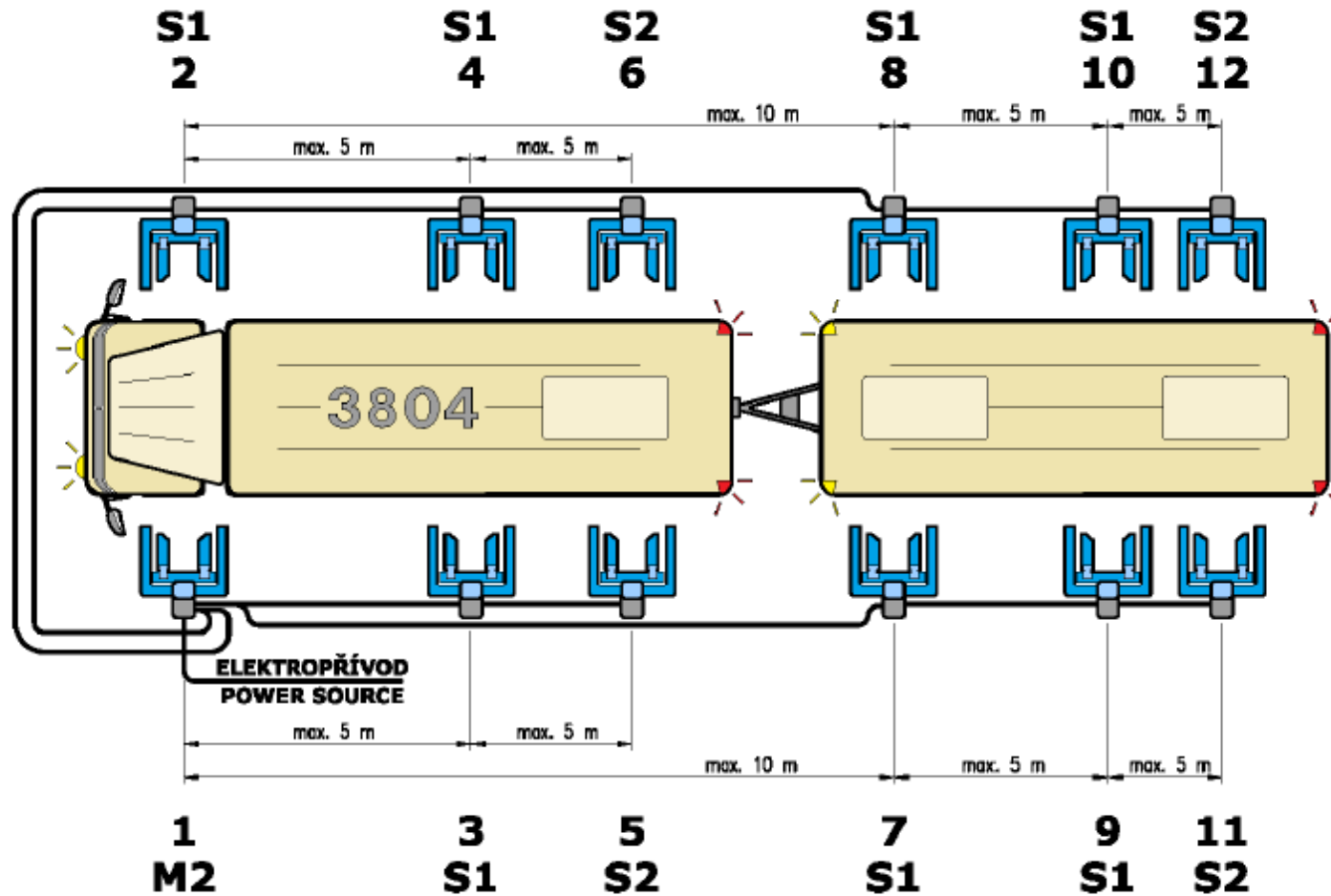



# SINGLE COLUMN HYDRAULIC LIFTS

## Tandem function

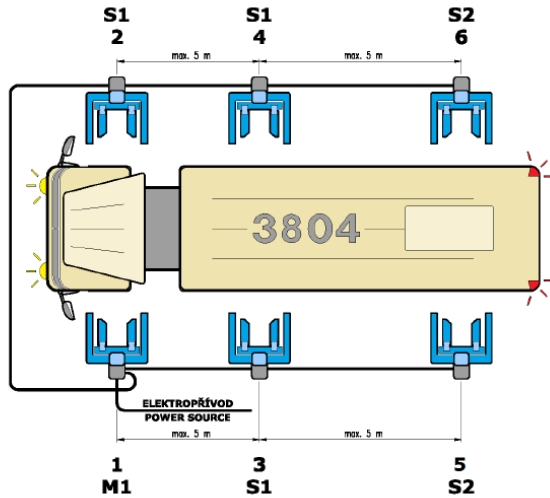

## 2 Independent sets

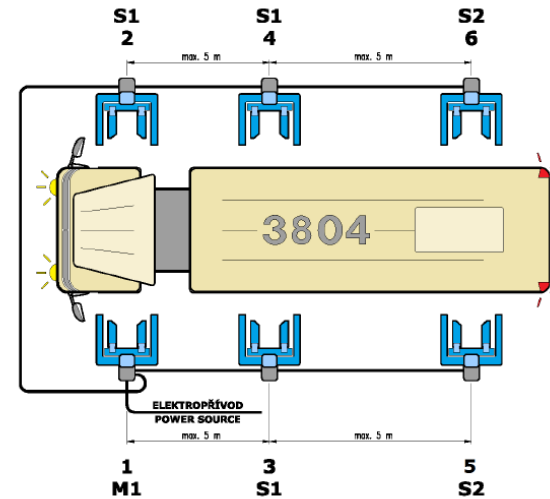

**2 Independent sets  
connected to work together  
operated by this Master  
column or by remote control**

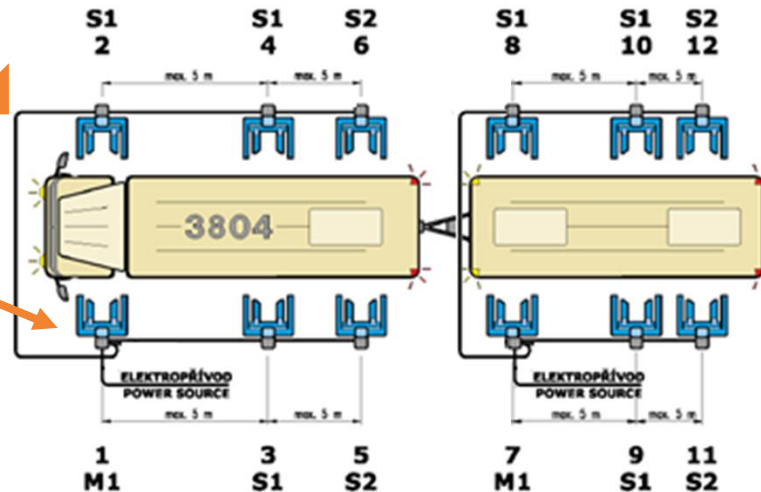



# SINGLE COLUMN HYDRAULIC LIFTS

Enlargement up to 12 columns

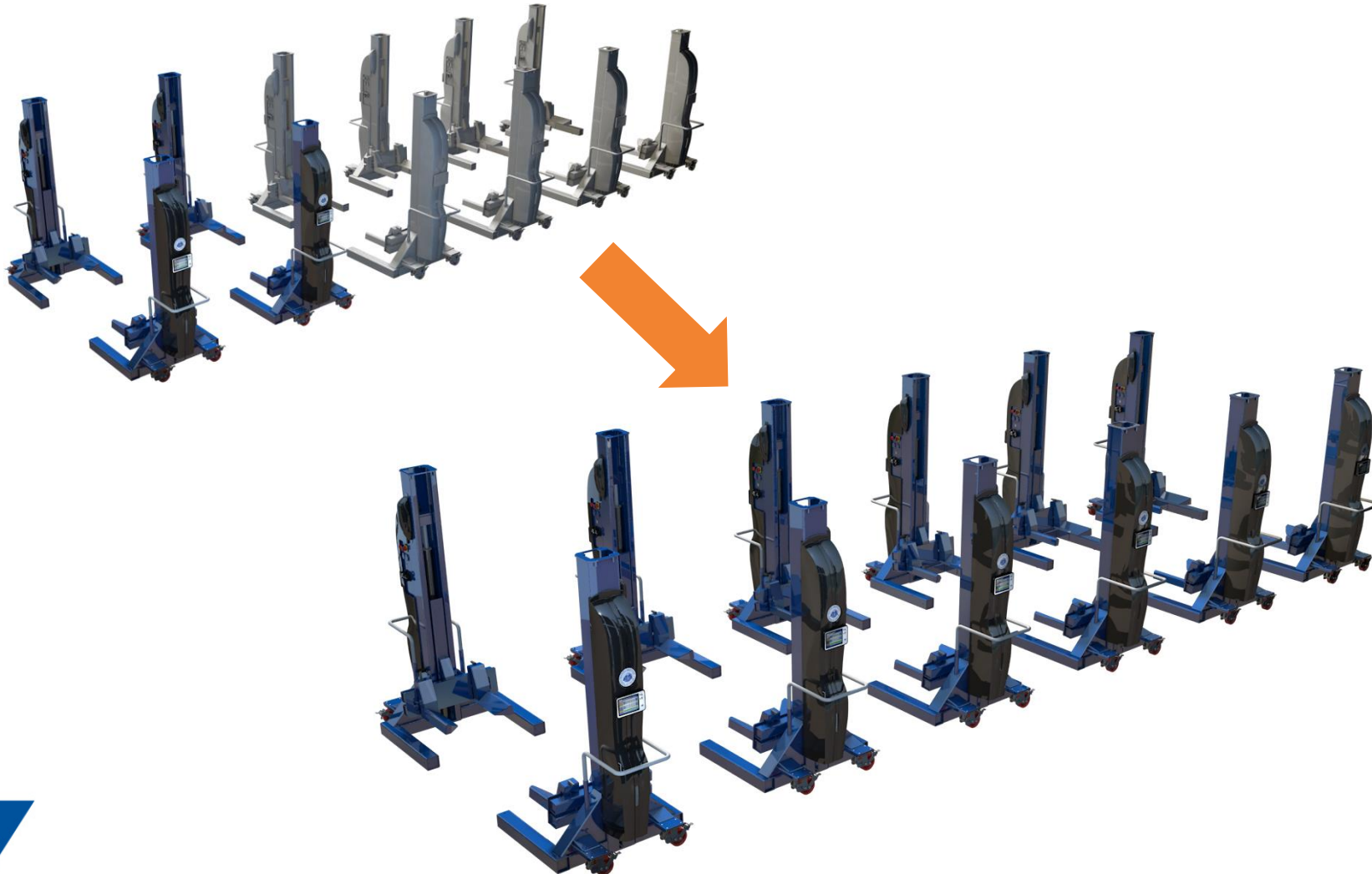



# SINGLE COLUMN HYDRAULIC LIFTS

## Accessories

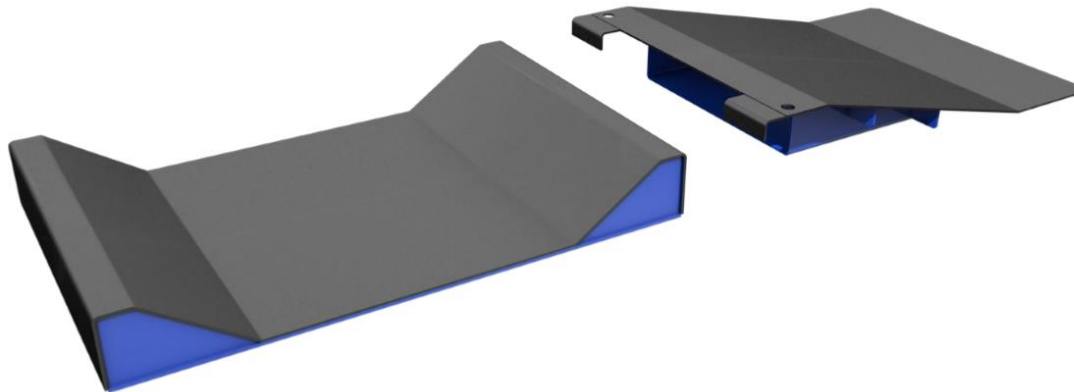



**SCANIA**







# ADVANTAGES OF COOPERATION

Direct dealing with the producer

Only company providing **10 year warranty** (1800+ lifts in CZ)

100% outcome quality check of all products

Pre-assembled lifts => short time of installation

Tens year of experience

Lifts produced in compliance with ČSN EN 1493:2010





# CONTACT

**AUTO MOTIVE INDUSTRIAL a.s.**

**Sokolovská 1169**

**570 01 Litomyšl**

**Czech Republic**

**[www.automotive.cz](http://www.automotive.cz)**

**Tel. +420 461 618 555-7**

**David KOUBA**

**Key Account Manager**

**M: +420 776 779 158**

**E: [kouba@automotive.cz](mailto:kouba@automotive.cz)**

